



## SSV KIT - Apache 360 LT Mounting

[Printable Version](#)

Rate This  
Article

(Average Rating:  
3)

Language [Show](#)  
English [Properties](#)

Product:	<b>Side-by-side</b>
Project no:	<b>tsi2014-008_rev5</b>
Instruction Sheet P/N:	<b>487800427</b>
Revision no:	<b>5</b>
Revision date:	<b>December 03, 2014</b>
Item covered:	<b>Apache 360 LT Mounting</b>

**The following symbols may be used in this document:**

### **⚠ WARNING**

Indicates a hazardous situation which, if not avoided, could result in death or serious injury.

**⚠ CAUTION:** Indicates a hazard situation which, if not avoided, could result in minor or moderate injury.

**NOTICE** Indicates an instruction which, if not followed, could severely damage vehicle components or other property.

### **⚠ WARNING**

- For safety reasons, this kit must be installed by an authorized BRP dealer.
- This kit is designed for specific applicable models only (authorized BRP dealers will confirm model(s)). It is not recommended for units other than the one (those) for which it was sold.
- Should removal of a locking device (e.g. lock tabs, self-locking fasteners, etc.) be required when undergoing disassembly/assembly, always replace with a new one.
- Torque wrench tightening specifications must strictly be adhered to.

**NOTE:** The illustrations in this document show typical construction of the different assemblies and may not reproduce the full detail or exact shape of the parts; however, they represent parts that have the same or similar function.

Installation time is approximately 2 hours.

## PARTS TO BE INSTALLED

Item	Description	Quantity
P1	M10 x 60 hexagonal screw (black)	2
P2	M10 Flat washer (black)	14
P3	M12 x 65 hexagonal screw (black)	2
P4	Sub-table plate with limiter (RH)	1
P5	M10 hexagonal nylon nut (black)	10
P6	Front top sub-table	2
P7	M10 x 50 hexagonal screw	2
P8	M10 x 40 hexagonal screw	2
P9	Rod end	2
P10	M12 hexagonal nut	2
P11	Anti-rotation assembly	2
P12	M16 hexagonal nut	4
P13	Front washer end	6
P14	Rubber bushing	12
P15	Spacer tube (front) Length: 146 mm (5-3/4 in)	2
P16	Overextension stopper cable	2
P17	Ball rod end spacer	2
P18	Short rod end spacer	2

P19	M12 hexagonal nylon nut	2
P20	Anti-rotation spring	2
P21	Spring washer I.D.: 20.6 mm (.811 in)	2
P22	Rubber bushing	2
P23	Spring washer I.D.: 16.5 mm (.65 in)	2
P24	M16 hexagonal nylon nut (black)	4
P25	Flexible guard (RH)	1
P26	Pop rivet	4
P27	Rear fixation assembly	2
P28	Spacer I.D.:14.3 mm (.563 in) Length: 11.1 mm (.437 in)	2
P29	Neoprene washer	2
P30	M10 x 45 hexagonal screw	2
P31	Tightening spacer I.D.: 19 mm (.748 in) Length: 18 mm (.709 in)	2
P32	Rear anti-rotation bar	2
P33	Spacer tube (Rear) Length: 134 mm (5.276 in)	2
P34	Flat washer	6
---	Sub-table plate with limiter (LH)	1
---	Flexible guard (LH)	1
---	Air intake pre-filter	See engine warranty requirement

---	Heat dissipation kit*	See heat dissipation
---	Track module	1

\*For Commander 2012 model year and older.

See BRP service parts catalog for part numbers and service kits.

## INSTALLATION INSTRUCTIONS

Installation is the same for left and right sides. The right hand (RH) side is shown in these instructions. If the part differs between the left and right side the correct side will be indicated in the table above (example: Sub-Table Plate With Limiter (RH) [P4]). Always refer to exploded view when in doubt.

### Front Mounting Kit Installation

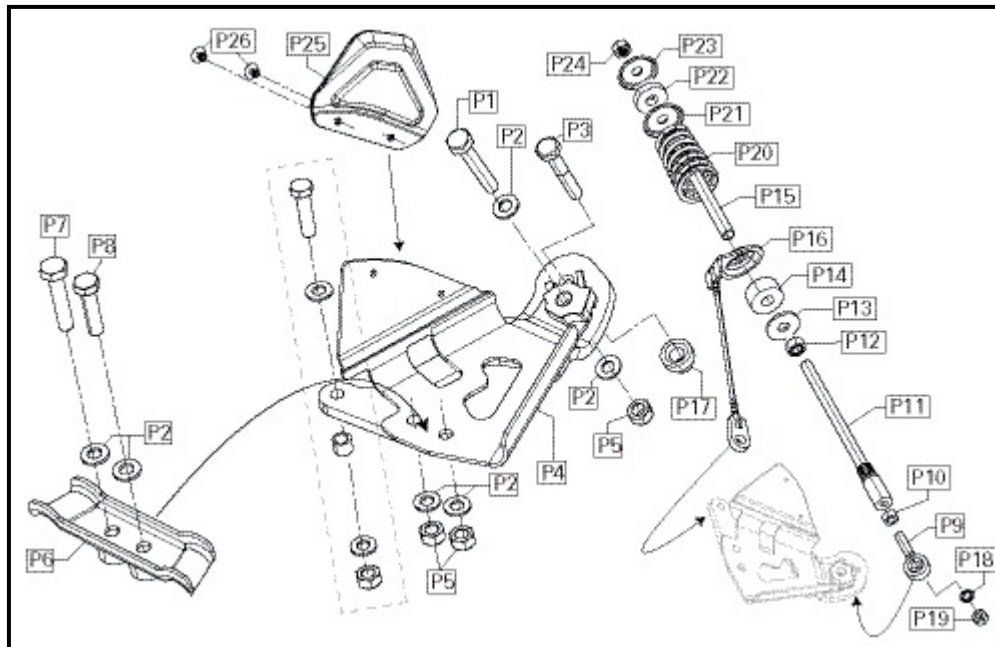

FRONT MOUNTING KIT - EXPLODED VIEW

1. With vehicle on the ground, remove A-arm protector.

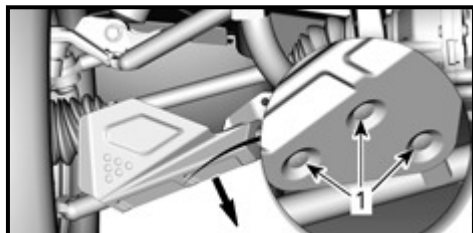

2. Install M10 x 60 hexagonal screw (black) [P1] and M10 Flat washer (black) [P2] through lower A-arm.

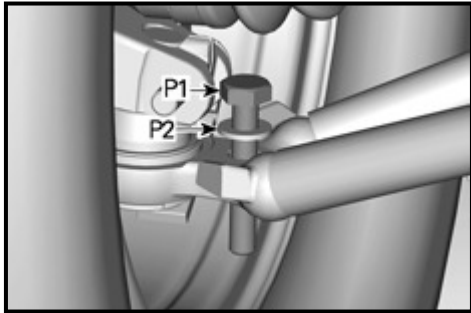

3. Raise vehicle and remove wheels.

4. Properly install M12 x 65 hexagonal screw (black) [P3] into sub-table plate with limiter (RH) [P4].

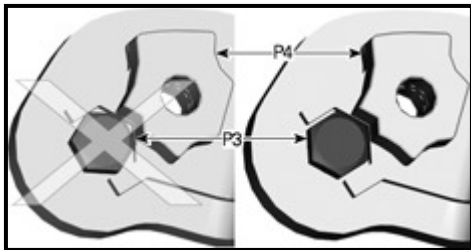

5. Install the following parts as illustrated.

**NOTE:** Install all nuts loosely, tighten only when indicated.

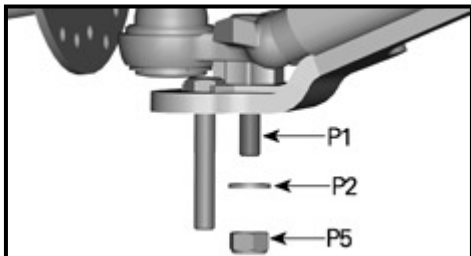
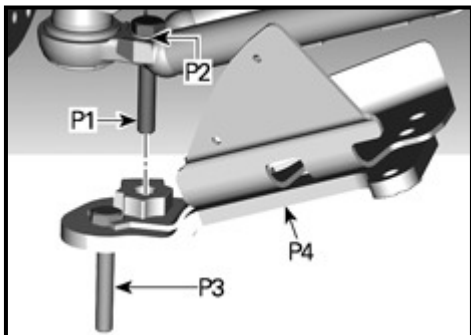

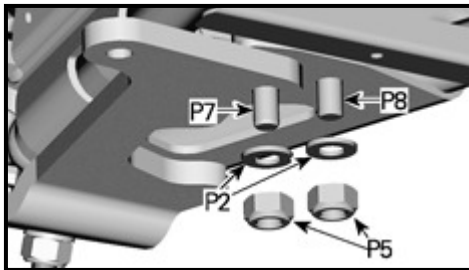
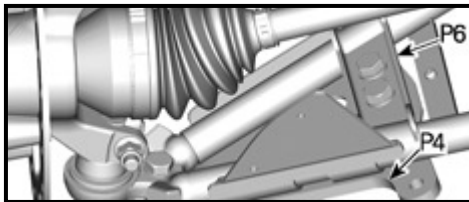
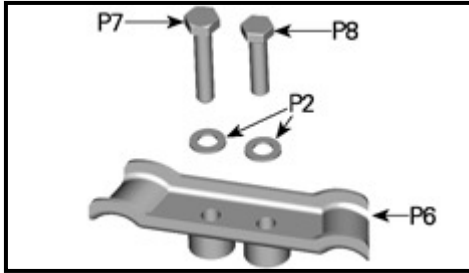

6. Tighten all M10 hexagonal nylon nuts [P5].

<b>Tightening Torque</b>	
M10 hexagonal nylon nut (black) [P5]	61 ± 9 N•m (45 ± 7 lbf•ft)

7. Install track on vehicle.



FRONT ASSEMBLED TRACK - RH

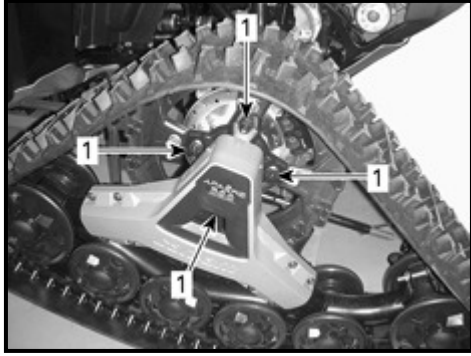

1. Lug nut

Tightening Torque	
Lug Nuts	$90 \pm 10 \text{ N}\cdot\text{m}$ ( $66 \pm 7 \text{ lbf}\cdot\text{ft}$ )

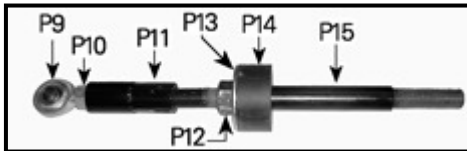

Tightening Torque	
M12 hexagonal nut [P10]	$85 \pm 10 \text{ N}\cdot\text{m}$ ( $63 \pm 7 \text{ lbf}\cdot\text{ft}$ )

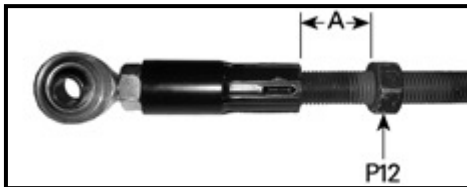

A. 25 mm (1 in)

8. Insert anti-rotation assembly into track metal bracket.



1. Metal bracket

9. Install overextension stopper cable [16] onto anti-rotation assembly.

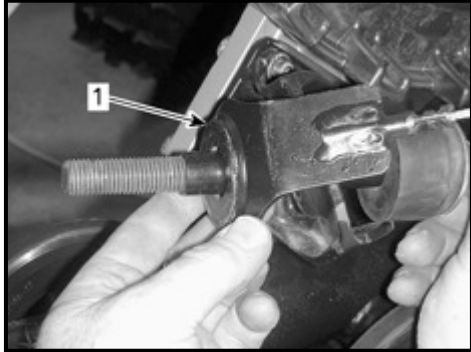

1. Overextension stopper cable [P16]

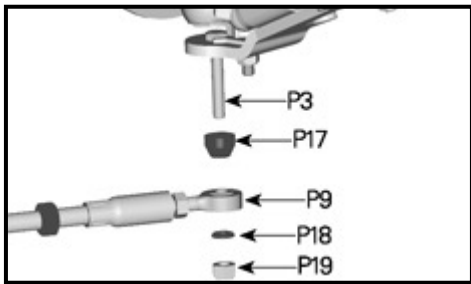

Tightening Torque	
M12 hexagonal nylon nut [P19]	105 ± 15 N•m (77 ± 11 lbf•ft)

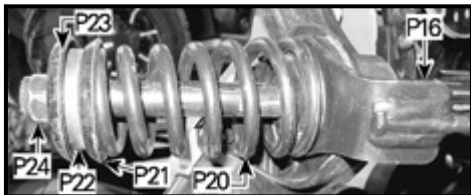

10. Do not tighten M16 hexagonal nylon nut [P24] yet. Tracks still need to be adjusted, see *TRACK ADJUSTMENT*.

11. Install flexible guard (RH) [P25] (part number facing rear) with 2 pop rivets [P26].

<p><b>⚠ WARNING</b> If flexible guard is improperly installed damage to brake system may occur.</p>
---

## Rear Mounting Kit Installation



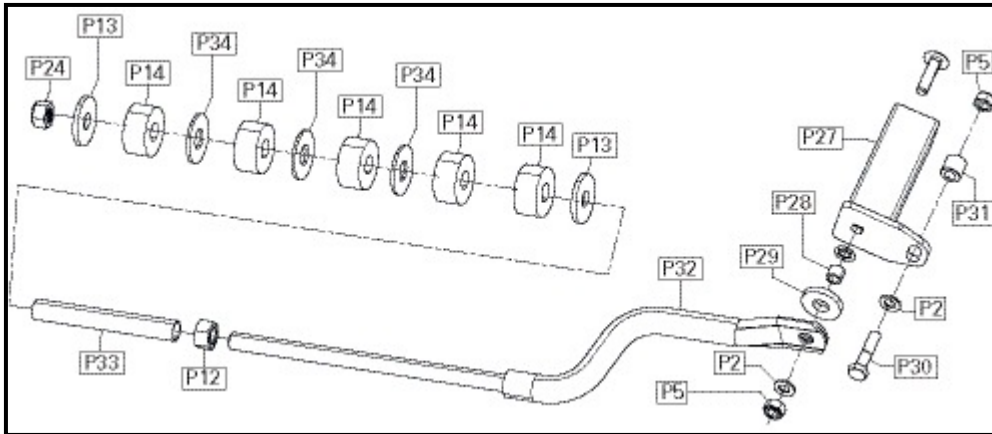

REAR MOUNTING KIT - EXPLODED VIEW

**NOTICE** If the vehicle is equipped with rock sliders they must be modified or removed.

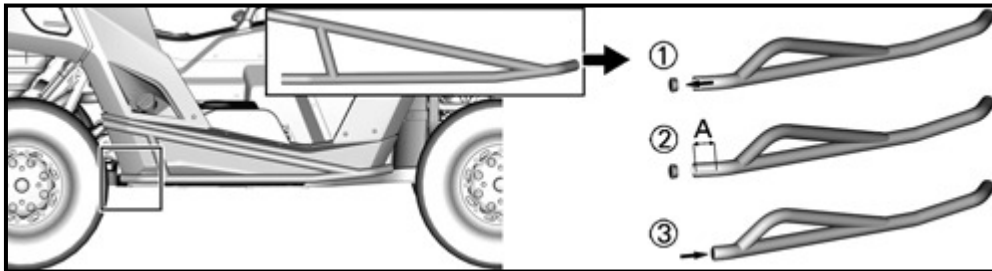

TYPICAL ROCK SLIDER MODIFICATION - BOTH MODELS SHOWN - RH SIDE

A. Remove 38 mm (1-1/2 in)

1. Remove both rear wheels.
2. Inspect frame.

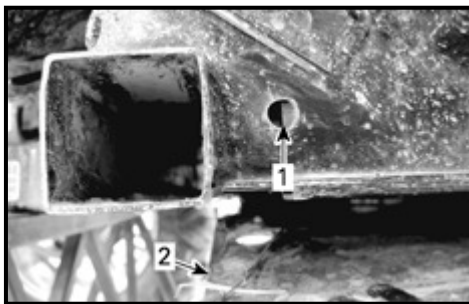

REAR RH FRAME

1. Hole must be clear
2. Skid plate

3. If needed, drill hole before inserting rear fixation assembly [P27].

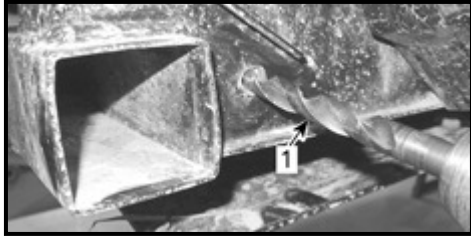

1. 10 mm (13/32 in)

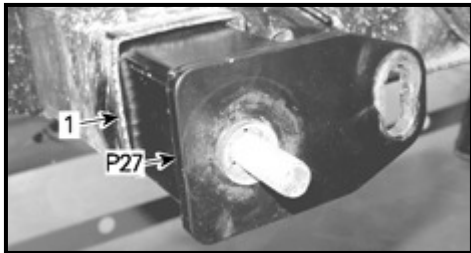

1. Rear RH frame

4. Tighten M10 x 45 hexagonal screw [P30] while holding M10 hexagonal nylon nut [P5] inside frame.

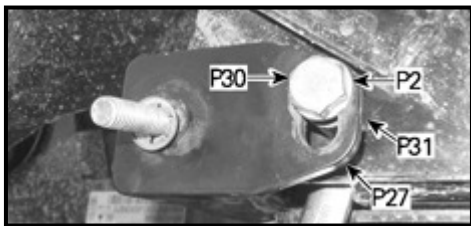

<b>Tightening Torque</b>	
M10 x 45 hexagonal screw [P30]	61 ± 9 N•m (45 ± 7 lbf•ft)

5. Install track on vehicle.

<b>Tightening Torque</b>	
Lug Nuts	90 ± 10 N•m (66 ± 7 lbf•ft)

6. Begin assembling rear anti-rotation bar and insert into track metal bracket as shown.

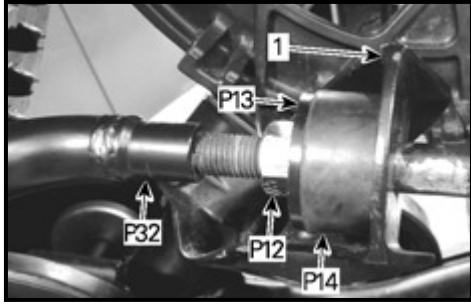

1. Tack metal bracket

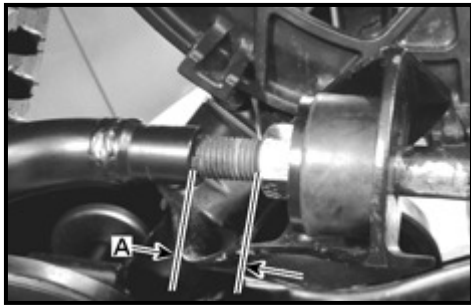

A. 12.7 mm (1/2 in)

7. Install other end of anti-rotation bar on rear fixation assembly.

**NOTE:** Do not forget about spacer [P28] (not visible here).

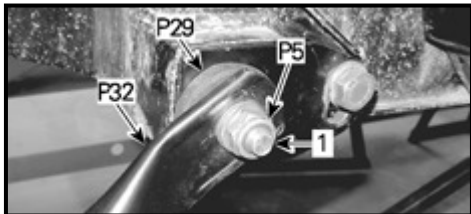

1. Bolt pre-assembled in [P27]

<b>Tightening Torque</b>	
M10 hexagonal nylon nut [P5]	48 ± 6 N•m (35 ± 4 lbf•ft)

8. Finalize assembling rear anti-rotation bar.

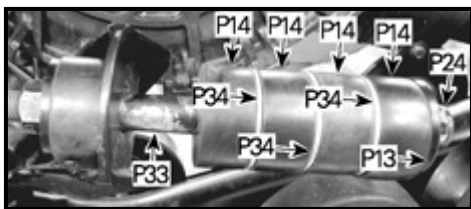

9. Do not torque M16 hexagonal nylon nut [P24] yet. Tracks still need to be adjusted, see *TRACK ADJUSTMENT*.

# Track Adjustment

## Front Adjustment

With the vehicle level on the ground.

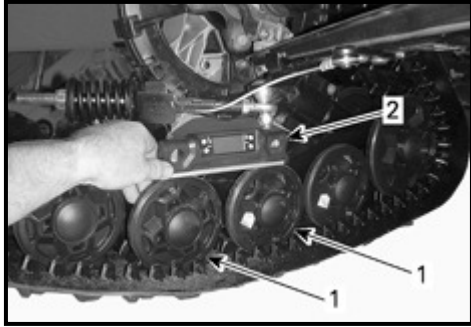

*TYPICAL*

1. 144 mm (5-11/16 in) central wheels
2. Level board

1. Adjust (tighten) rear hexagonal nut on anti-rotation assembly arm to bring the two 144 mm (5-11/16 in) central wheels to a 2° - 4° angle towards the front of the vehicle.

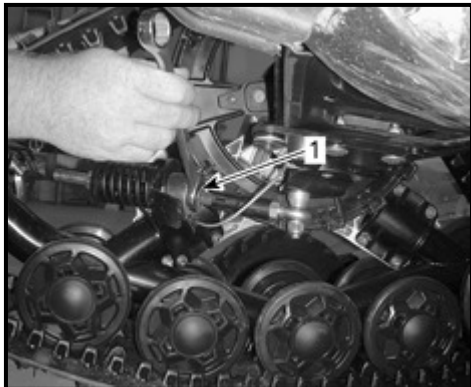

*TYPICAL- INSIDE OF WHEEL*

1. Rear hexagonal nut

**NOTE:** The top of 190 mm (7-1/2 in) rear wheel should be raised to  $260 \pm 4$  mm ( $10-15/64 \pm 5/32$  in) from ground.

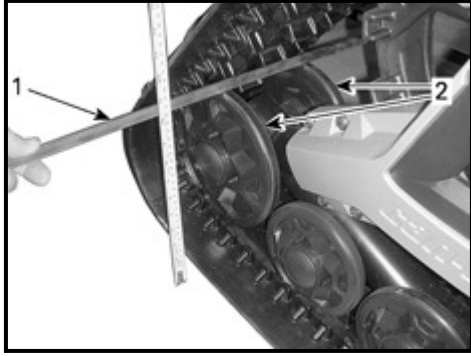

TYPICAL

1. Top of 190 mm (7-1/2 in) wheel
2. 260 ± 4 mm (10.236 ± .157 in) mark

2. Tighten M16 hexagonal nylon nut [P24] to specification.

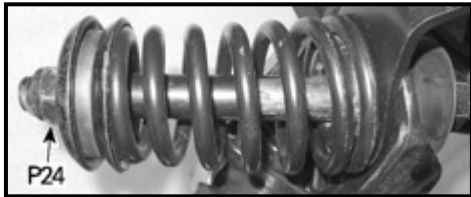

<b>Tightening Torque</b>	
Hex Nylon Nut M16 (black) [P24]	65 ± 5 N•m (48 ± 4 lbf•ft)

## Rear Adjustment

With the vehicle level on the ground.

1. Tighten M16 hexagonal nylon nut [P24] until the rear rubber bushings touch the track metal bracket; bushings will not make even contact with track metal bracket.

**Translation: New pict**

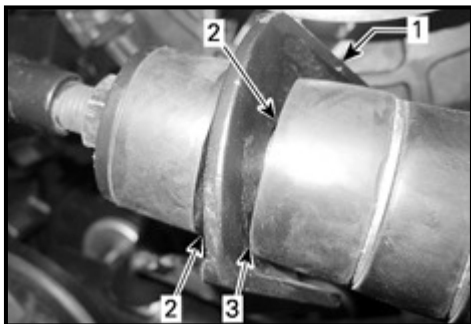

1. Track metal bracket
2. Normal gap
3. Rubber bushing making contact

2. Mark location of M16 hexagonal nylon nut [P24] on rear anti-rotation tube.

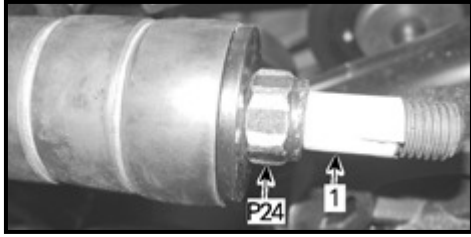

1. Tape mark

3. Tighten nut M16 hexagonal nylon nut [P24] until rubber bushing stack compresses by 9.5 mm (3/8 in).

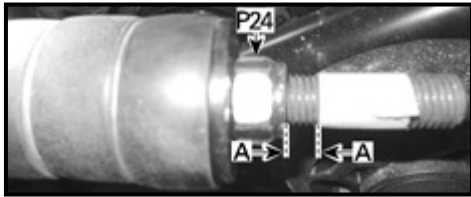

A. 9.5 mm (3/8 in)

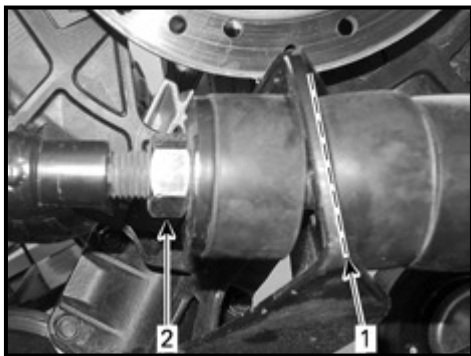

1. No gap here with [P24] tightened 9.5 mm (3/8 in)  
 2. [P12] to tighten in following step

4. Tighten M16 hexagonal nut [P12] until tight on spacer tube (Rear) [P33].
5. Ensure torque on M16 hexagonal nylon nut [P24] is within specifications.

<b>Tightening Torque</b>	
M16 hexagonal nylon nut [P24]	$65 \pm 5$ N•m ( $48 \pm 4$ lbf•ft)

## Steering Alignment Verification

1. Compress front suspension several times to settle suspension and tracks.
2. Check that steering wheel is straight.
3. Measure the distance at the front of front track assembly A.
4. Measure the distance at the rear of front track assembly B.

**NOTE:** The perfect toe-out adjustment A – B, at the front of tracks A, should be  $0 \pm 13$  mm ( $0 \pm .5$  in).

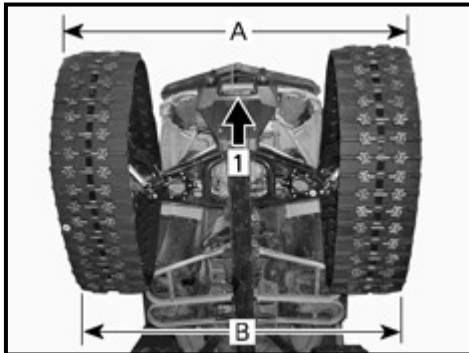

TYPICAL

A. Measure distance at the front

B. Measure the distance at the rear

1. Front of the vehicle

**NOTE:** If steering alignment is out of specification, align vehicle.

### **⚠ WARNING**

Vehicle steering alignment must be performed by an authorized Can-Am SSV dealer.

## **Track Tension**

Track tension must be inspected and adjusted periodically.

For a full list of periodic maintenance procedures please refer to your *OWNER'S MANUAL*

## **Track Module**

Installation of a separate Track Module is required with the Apache 360 LT track kit. Refer to *TRACK MODULE* instruction sheet.

When installed on a vehicle with a standard steering system (no DPS system), the sole purpose of the track module is to re-calibrate the speed and distance indications in the gauge to compensate for the lower gear ratio produced by the Apache 360 LT track kit.

When installed on a vehicle with a DPS system, the module serves the same purpose as with a manual steering system, but also produces a desirable secondary effect.

Due to the lower indication of vehicle speed that is transmitted from the multifunction gauge to the DPS module, the DPS assist levels will be increased.

## **CVT Air Intake Duct**

When riding in powder snow, CVT air intake filter can clog. To prevent from overheating, unplug plastic air duct from rubber filter support located over driver foot area near steering column. Put plastic air duct over rubber boot lips.

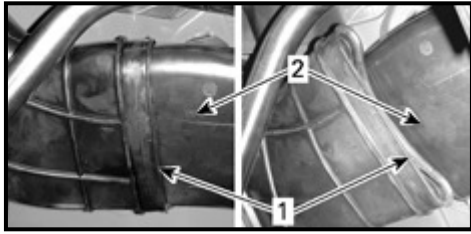

CVT AIR INTAKE DUCT

- 1. Rubber filter support
- 2. Plastic air duct

## Engine Warranty Requirement

When fitting this Apache 360 LT track kit to Can-Am Commander models, an INTAKE PRE-FILTER KIT MUST BE INSTALLED.

NOT DOING SO WOULD VOID THE WARRANTY.

Required Part	
Air intake pre-filter	(P/N 715 000 953)

## Heat Dissipation

*Commander model year 2012 and older*

When riding in severe conditions or when vehicle is used intensively, a CARGO HEAT DISSIPATION KIT FOR SEVERE DUTY APPLICATION MUST BE INSTALLED.

Required Part	
Cargo heat dissipation kit for severe duty application	(P/N 703 500 810)

## Safety Labels

This product comes with the following bilingual safety label already installed containing important safety information.





LABEL 1

Any person who intends to use this product should read and understand the information contained on the labels before doing so.

The labels should be considered permanent parts of this product. If the labels come off or become hard to read, please contact an authorized Can-Am SSV dealer for FREE-OF-CHARGE replacement.

## Location of Safety Labels

Refer to the following picture for the location of the safety labels.

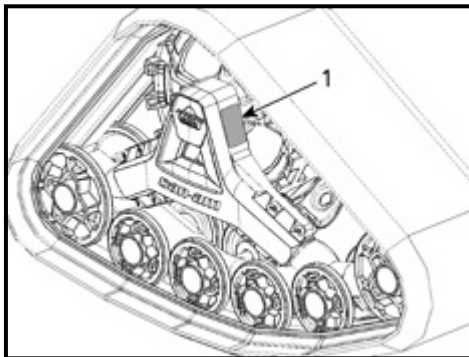

TYPICAL- FRONT AND REAR TRACK ASSEMBLY

1. Label location

## Track Removal Procedure

1. Lift vehicle and secure in place.
2. Remove and keep lug nuts.
3. Remove front tracks, sub tables and anti-rotation assemblies. Keep overextension stopper cable attached to lower sub-tables.
4. Remove rear tracks, anti-rotation bars and rear fixation assemblies.
5. Install front suspension protectors.

**NOTICE** Always install suspension protectors when removing tracks to avoid damage to the drive shaft boots.

6. Install wheels onto vehicle.
7. Torque lug nuts to specifications.

<b>Tightening Torque</b>	
Lug Nuts	90 ± 10 N•m (66 ± 7 lbf•ft)

8. Remove track module.

---

2099-12-04